



**OPERATING INSTRUCTIONS  
MODEL DA-1500  
MAGNETIC INSPECTION UNIT**

**BULLETIN 262-1500  
June 2024**

**PARKER RESEARCH CORP.**

NONDESTRUCTIVE TEST METHODS, SYSTEMS, INSTRUMENTS  
BOX 1406, DUNEDIN, FLORIDA, U.S.A. 34697  
PHONE: (727)796-4066 FAX: (727)797-3941

**THE CONTENTS OF THIS MANUAL MUST BE READ AND FULLY UNDERSTOOD BEFORE  
INSTALLATION, OPERATION OR MAINTENANCE OF THIS EQUIPMENT. FAILURE TO DO  
SO MAY RESULT IN INJURY.**

**INTRODUCTION**

The DA1500 Magnetic Inspection Unit is a portable power pack designed to furnish high amperage, low voltage AC current and Half-Wave current for Magnetic Particle inspection. It features infinitely variable magnetizing and demagnetizing current.

**THE FOLLOWING SHOULD BE READ AND FULLY UNDERSTOOD.**

SAFETY PRECAUTIONS	PAGE 2
GENERAL DESCRIPTION	PAGE 2
ELECTRICAL FEATURES	PAGE 3
CONNECTION	PAGE 3
CONTROLS-ELECTRICAL	PAGE 4
OPERATION	PAGE 5
SERVICE DATA & WARRANTY	PAGE 6
SCHEMATIC DIAGRAM	PAGE 7-8

Parker Research Corporation assumes no liability from any claims arising from the use of this equipment.

**CAUTION:** For the correct and safe use of this equipment, proper training of operating personnel to required inspection techniques, specifications and safety requirements is necessary and is the obligation of the user.

## **SAFETY PRECAUTIONS**

The following safety precautions must be fully understood and applied during the installation, operation and maintenance of this equipment. These safety precautions appear throughout the text and are covered here for emphasis.

- A. "**DANGER**" Ground this equipment before operating. Failure to ground this unit properly may result in electrical shock hazard.
- B. "**CAUTION**" Use safety glasses when operating this equipment.
- C. "**DANGER**" Line current must be disconnected before equipment panels are removed for any reason. Only qualified electrical personnel should attempt service.
- D. "**CAUTION**" When performing prod inspection with this unit, use very firm contact pressure to minimize chances of arcing.
- E. "**WARNING**" This equipment produces a strong electromagnetic field which can be harmful to people with implanted Cardiac Pacemakers and implanted medical devices. Personnel with such devices should not operate this machine and must stay a safe distance away from this machine and cable output area. Contact the manufacturer of your Pacemaker for additional precautions and warnings.

## **GENERAL DESCRIPTION**

The DA1500 is a extremely rugged and compact Magnetic Inspection unit.

All operating controls and output terminals are located on the front panel. Two carrying handles are provided. One on the rear of the unit; the other is a swivel handle located at the front of the unit. This handle may also be positioned to raise the front of the unit for ease of meter reading and operation.

Current output is approximately 1500 amperes low voltage AC and approximately 1500 amperes half-wave DC. The current output is based on the use of 30 feet (two 15') cables as a load. Current levels will vary dependent on cable length.

Optional magnetizing cables can be equipped with prods for circular magnetization. The cables can also be wrapped around parts to form a "coil" for longitudinal magnetization. Demagnetization is accomplished in a similar manner.

## **ELECTRICAL FEATURES**

The DA1500 unit is built to operate from either 230VAC or 460VAC (not interchangeably), 50/60 Hz., Single phase current. Line current at rated output is approximately 45 amperes at 230 volts and 23 amperes at 460 volts. Check "Data Nameplate" on the unit for correct operating voltage.

The DA1500 is sold without a power cord plug. Only locally approved plugs with the proper rating should be used and installed by certified personnel.

The DA1500 is wired at the factory for either 230VAC or 460VAC operating voltage. Change over from one voltage to another can not be done in the field. Unit must be returned to the factory for modification.

A manual circuit breaker is provided to prevent overheating and damage to electrical components.

The current control potentiometer in conjunction with internal electrical circuit, provide infinitely variable magnetizing and demagnetizing current control.

The power transformer operating in conjunction with an SCR module, transforms the high voltage line input to low voltage, high amperage AC or Half-Wave DC output. While these components are fan cooled, they are designed for intermittent service at 1500 amperes output. To avoid overheating and possible damage, a maximum duty cycle of 10% must be adhered to.

**CAUTION:** Attaching less than 30' of 4/O cable (two 15' cables) may cause excessive line current draw and possible overheating of parts.

## **CONNECTION**

1. With current control and breaker in the "Off" position, connect the line cord to the properly fused and grounded disconnect switch of proper rating. Consult "Data Nameplate" on the back of the unit for correct operating voltage.
2. Turn the breaker to the "ON" position then turn the current control so that the unit powers "On". A red pilot light will glow indicating that there is power to the unit and that it is "On".
3. Plug in and twist clockwise two 15' 4/O magnetizing cables into the output connectors at the front of the unit. **Note:** One cable must be connected to the "Common" connector. The other cable must be connected to either the AC or HWDC cable connector. Connect the two eitherend connectors or two lug connectors at the opposite end of the cables to form a "loop". Plug in the control cable and activate to check operation for both AC and DC output.

For maximum output on either AC or half-wave DC, it is necessary to reduce the inductive loop of the external cables as much as possible; that is, the spacing between the external 4/O cables must be kept at a minimum. If possible, the first ten feet of cable may be bound or taped together for optimum current output. **NOTE:** When cables are used as a coil with AC current, ammeter readings will be lower due to coil/part inductance.

4. To power off turn the current control to the "Off" position. The red pilot light will go out indicating that the unit is "Off". Turn the breaker to the "Off" position then turn off the disconnect switch that the line cord is connected to.

## **CONTROLS - ELECTRICAL**

### **CURRENT CONTROL/RED PILOT LIGHT**

This is the main switch, located next to the ammeter on the front panel. With the current control in any position other than "Off", the red pilot light will glow indicating that the unit is ready for operation. Current values will be indicated by the ammeter reading when the external magnetizing circuit (loop) is complete.

### **CIRCUIT BREAKER**

This control is located on the back of the unit. It will interrupt the current to the unit whenever the rated amperage of the circuit breaker is exceeded.

### **AMMETER**

The ammeter, located on the front panel, registers the current flowing in the magnetizing circuits. An automatic solid state switching circuit allows a single meter to provide accurate current readings for both AC and half-wave DC magnetizing currents.

### **OUTPUT CONNECTORS**

Half-wave DC current is obtained by connecting the magnetizing cables to the "Common" and "Half-Wave" connectors. A.C. current is obtained by connecting to the "Common" and "AC" connectors. Always insert and then twist cable connectors clockwise to lock in position.

### **CONTROL CABLE RECEPTACLE**

This receptacle is located below the current control. Twist and lock the control cable in the receptacle.

### **PROD CONTROL SWITCH**

Various optional prod assemblies have a control switch built into the handle. It is connected through a 20' cable and three prong twist lock plug to the control cable receptacle. It controls the magnetizing current through the prods.

### **REMOTE CONTROL CABLE SWITCH**

The optional remote control switch is attached through a 20' cable and activates the unit with a push button switch. This switch is required when using cables as a coil.

### **CONTROL CIRCUIT FUSE**

This fuse is located on the rear panel. Replacement can be accomplished from the outside. After power has been turned off, unscrew the head of the fuse holder. Remove the fuse from the holder by pulling out the fuse. Replace with a new fuse of proper rating and place back into holder. Replace fuse holder head. This fuse will interrupt the 115 volt control circuit in the event of an overload.

## **OPERATION**

### **COIL MAGNETIZATION**

1. Attach (2) 15' lengths of 4/O cable to the appropriate connectors of the front panel.
2. Wrap three turns of a 15 foot cable around or through the part to be inspected. Connect in series with the two other cables to form a 30 foot closed circuit.
3. Plug remote control cable into "Control Cable" receptacle. Use switch to control magnetizing current.
4. Turn current control to position that provides desired current level.
5. Apply magnetic inspection powder or bath to the surface to be inspected while current is on. Inspect for lines of magnetic particle build-up indicating circular defects.

### **PROD MAGNETIZATION**

1. Attach two 15' lengths of 4/O cables to appropriate connectors on front panel.
2. Plug prod control cable into "Control Cable Receptacle".
3. Turn current control to position that gives desired current level.
4. Make prod contacts with clean surface of part. Place prod tips approximately six inches apart on either side of the line of suspected defect. Press prod handle switch to initiate current flow. Use very firm contact pressure to minimize chances of arcing and burning. Ammeter will indicate magnetizing current.
5. Apply magnetic powder to the surface while magnetizing current is on.
6. Release prod handle switch to stop current flow. Remove prods from parts.

### **DEMAGNETIZATION**

Connect a formed coil to the AC and common output terminals. Set the current control to desired current level. Depending upon the size, the part is either passed through the coil, or the coil is passed completely over the part and slowly withdrawn while current is on. As the part or coil is withdrawn, the diminishing intensity of the AC field completes the demagnetization.

## SERVICE DATA

Each DA1500 is thoroughly tested and adjusted before shipping from the factory. However, while operators and maintenance department personnel should be familiar with the function of the electrical circuits, only authorized personnel should attempt to adjust or repair the unit.

## WARRANTY

The DA1500 is warranted against malfunction due to defective material and workmanship. The warranty shall cover repair or replacement of the DA1500 at no charge (less incoming freight charges) for a period of one (1) year from the date of purchase. Warranty will not apply to units that have been altered or to those units that have been used improperly.

In the event of malfunction, return the unit (prepaid) to the factory. Repair or replacement of the defective unit will be made at the discretion of Parker Research Corporation. The repaired or replacement unit will be returned to the original purchaser prepaid. **Note:** Do not return cables or prods with defective unit.

SHIP TO:  
PARKER RESEARCH CORPORATION  
2642 ENTERPRISE ROAD WEST  
CLEARWATER, FLORIDA 33763

ATTENTION: REPAIR DEPT.

1	RECONFIGURE S1	8-26-2006
2	DIGITAL METER & POWER BOARD	1-1-2015
3	OVERLOAD RELAY REMOVED, CIRCUIT BREAKER ADDED	12-1-2021

### CAUTION!

OUTPUT CURRENT IS EFFECTED BY CONFIGURATION AND LENGTH OF CABLE. A CABLE LENGTH OF NOT LESS THAN 30 FT. OF 4/0 CBALE IS REQUIRED. SHORTER LENGTHS WILL RESULT IN OUTPUT CURRENT EXCEEDING 1500 AMPS.

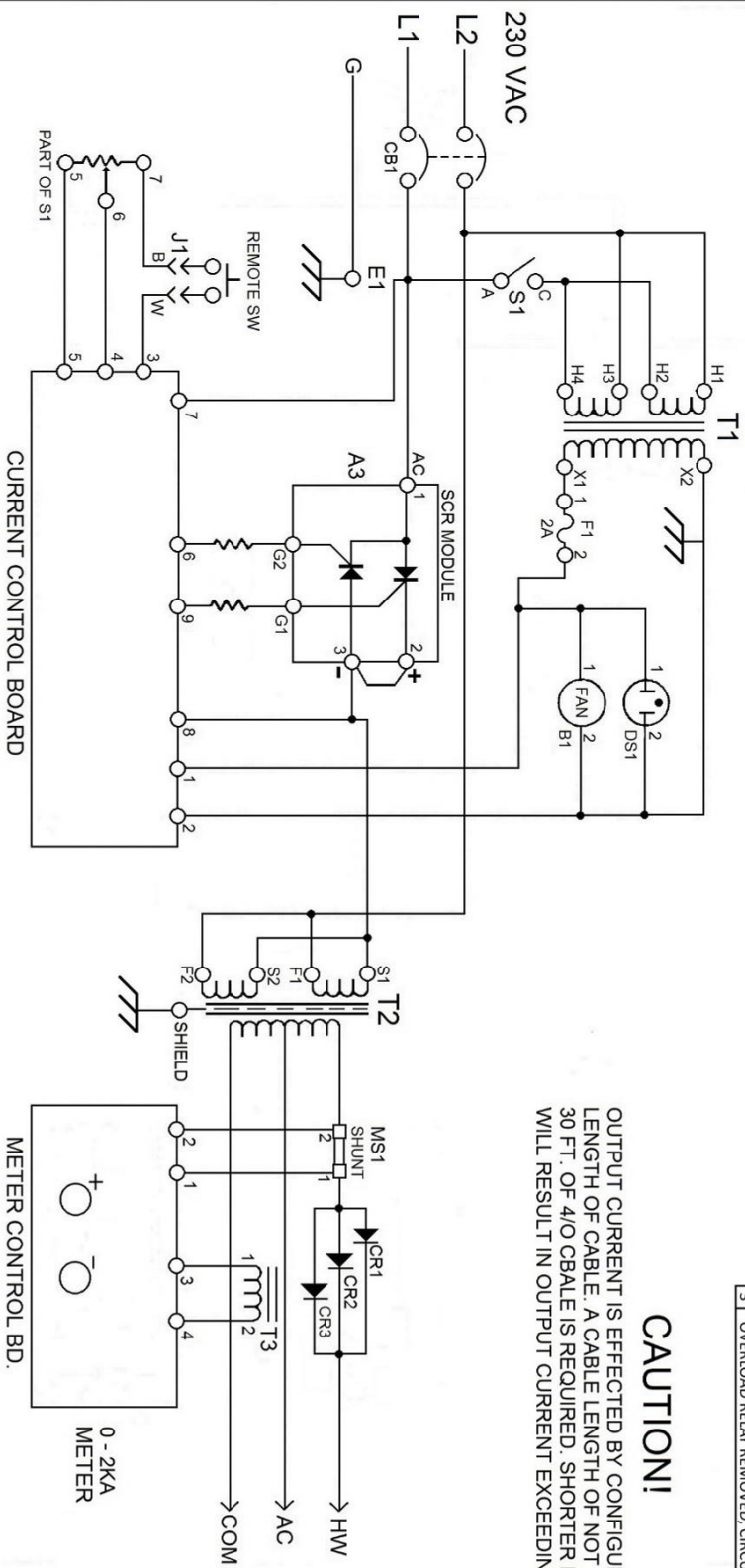

<b>PARKER RESEARCH CORP.</b>	
DWN BY: <i>KP</i>	APPR BY:
DATE: 10-23-2002	DATE:
<b>SCHEMATIC DIAGRAM</b>	
DA1500-230	
DWG NO. 2552	REVISED:
SCALE: —	SHEET 1 OF 3
	REV NO. 3

1	RECONFIGURE S1	8-26-2006
2	DIGITAL METER & POWER BOARD	1-1-2015
3	OVERLOAD RELAY REMOVED, CIRCUIT BREAKER ADDED	12-1-2021

**CAUTION!**

OUTPUT CURRENT IS EFFECTED BY CONFIGURATION AND LENGTH OF CABLE. A CABLE LENGTH OF NOT LESS THAN 30 FT. OF 4/0 CBALE IS REQUIRED. SHORTER LENGTHS WILL RESULT IN OUTPUT CURRENT EXCEEDING 1500 AMPS.

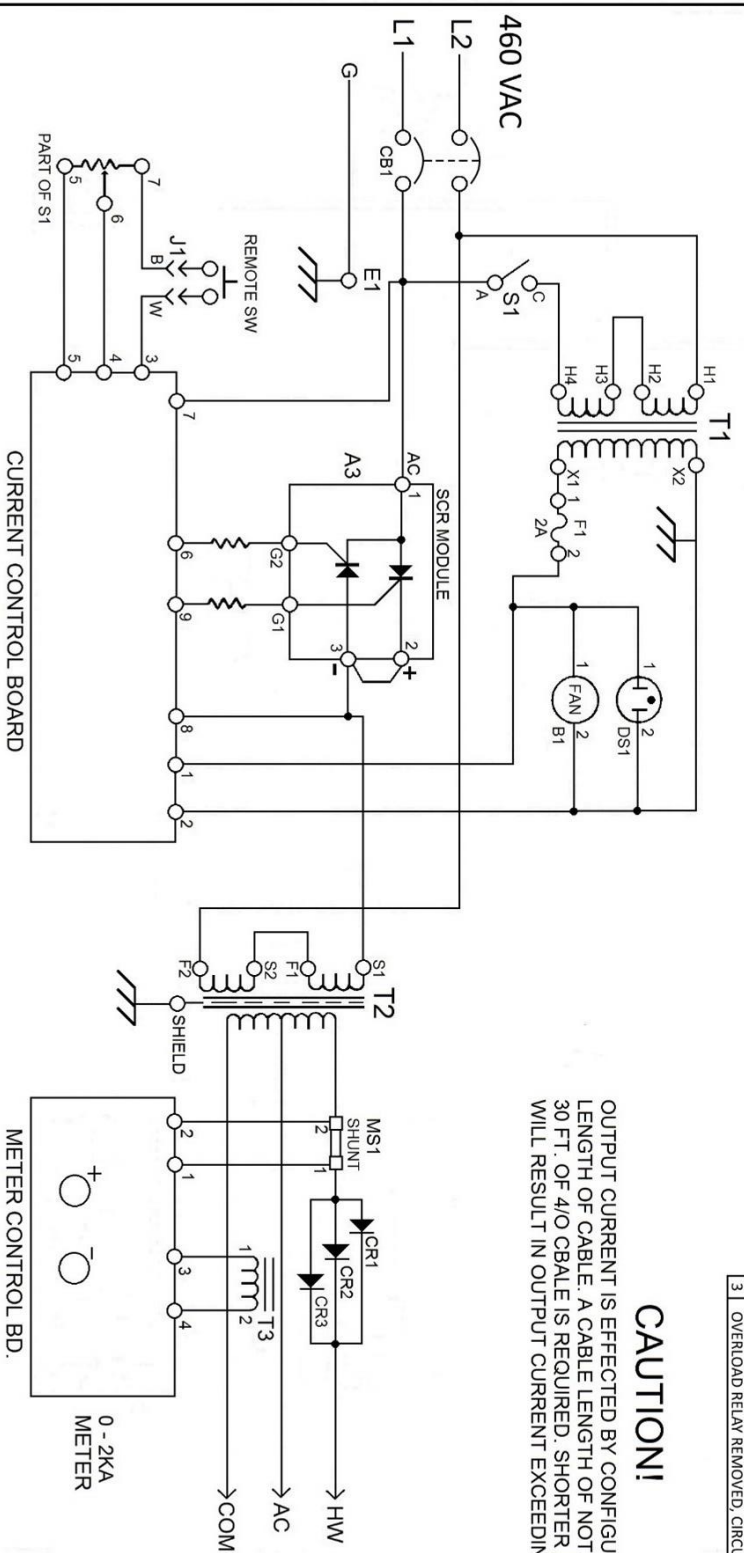

<b>PARKER RESEARCH CORP.</b>			
DWN BY: <i>KR</i>	APPR BY:		
DATE: 10-23-2002	DATE:		
<b>SCHEMATIC DIAGRAM</b>			
DA1500-460			
DWG NO. 2553	REVISED:		
SCALE: —	SHEET 1 OF 3	REV NO.	3