



OPERATING INSTRUCTIONS MODEL B310PDC CONTOUR PROBE

BULLETIN 269-1
May 2016

PARKER RESEARCH CORP.

NONDESTRUCTIVE TEST METHODS, SYSTEMS, INSTRUMENTS
BOX 1406, DUNEDIN, FLORIDA, U.S.A. 34697
PHONE: (727)796-4066 FAX: (727)797-3941

The **B310PDC (Pulsed D.C.)** Contour Probe is a very portable, battery operated Magnetic Inspection Yoke designed for Magnetic Particle inspection. It is especially convenient for use where outside power is unavailable or where operator safety is a concern.

INSTRUMENT DESCRIPTION: The B310PDC Contour Probe is an electromagnet that produces a strong Pulsed D.C. magnetic field. A circuit board contained within the Probe assembly produces a high frequency Pulsed D.C. field. All Parker Contour Probes are designed with flexible legs that allow the field to be "focused" at a precise area of inspection. The maximum leg spacing is 9 inches (228.6 mm). The 310PDC series Contour Probe comes equipped with a 6' (1.82 m) power cord.

Although this Pulsed field produces more defined defect indications over that of a pure D.C. field, the Pulsed D.C. field may not in all instances produce the same sensitivity to detect minute defect indications that might otherwise be obtained by an A.C. field. Further, the Pulsed D.C. field does not capture the magnetic field width of the surface test area that is obtained with A.C. Care should be taken to test for defects in a line between the poles (legs) upon the work surface.

BATTERY PACK: The B310PDC operates from a 12VDC battery.
Parker Battery Packs: P/N: BP-7 (7.2 Amp Hour) and P/N: BP-15 (14.4 Amp Hour).

CAUTION: To dispose of old batteries, follow the regulations of local ordinances

NOTICE: Always refer to applicable standards requirements for intended use and application. Tests shall be performed to determine acceptable system performance.

Specifications

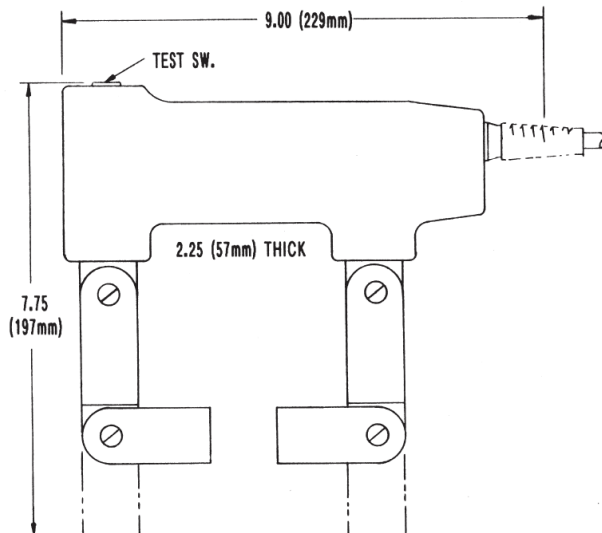

MODEL	POWER REQUIREMENTS	FIELD	WEIGHT
B310PDC	12VDC	DC ONLY	6 lbs. (2.72 kg)

GENERAL SAFETY RULES

Please read all instructions. Failure to follow all instructions listed below may result in injury. If the equipment is used in a manner other than as specified in these operating instructions, the protection provided by the equipment may be impaired. Always wear eye protection

Do not abuse the power cords. Never carry the instrument by the cord or attempt to unplug the instrument using the cord. Always operate the instrument with the standard installed cord. Changing or using a damaged cord can increase the risk of electrical shock. The cord should be checked periodically for any damage.

Do not position the instrument such that it would be difficult to operate the disconnect device (plug) on the end of the power cord.

The outside housing should remain intact and solid. Any damage, chipping, or separating exposing internal wires is a hazard. Instruments should not be used in this condition. The outside housing should be periodically checked for damage.

Duty Cycle: The 310PDC series are designed for a 50% duty cycle. Continuous operation may cause overheating and damage the Contour Probe.

Operating Environment: Temperature: 32° to 104°F (0° to 40°C). Relative humidity: 10% to 95%, non-condensing.

Shipping and Storage Environment: Temperature: 40° to 140°F (4.44° to 60°C). Relative humidity: 5% to 95%. Vibration and shock: As encountered in normal shipping and handling with no degradation

General Cleaning

The outside surface of the instrument can be periodically wiped with a clean cloth and a mild general purpose cleaner. Avoid using cleaners such as lacquer thinner, or mineral spirits that could damage the outside housing.

Never attempt field service. All B310PDC contour probes should be returned to the factory for repairs.

OPERATION: Connect the instrument plug into the power outlet of the proper battery. Place the Contour Probe legs upon the work surface with the suspected defect at right angles to the legs (Good contact will produce the best results). Push the test switch to energize the instrument. Lightly dust or float dry magnetic inspection powder over the area being inspected between the poles (legs). Turn the Probe 90 degrees from the first test and repeat the process. This method may also be utilized when applying a wet medium. Check all procedures and standards for further details involving inspection specifics.

ELECTRICAL: The B310PDC obtains its power from a portable 12V battery. A green "Battery Level" LED is located at the rear of the unit. Should the battery voltage drop to an insufficient level, the light will go out indicating that charging is necessary. Additionally, if the green LED fails to light with a sufficiently charged battery, it is an indication that there is a malfunction with the internal circuit or with the connection to the battery. If a malfunction is suspected, the instrument should be returned to the factory for repair. The 7.2 amp hour battery should remain at sufficient charge for approximately eight hours or longer depending on use. The 14.4 amp hour battery should last nearly sixteen hours or more.



CAUTION: Small parts may become magnetically saturated due to excessive field application. This may cause a masking effect to the point where it is impossible to define a defect.

WARRANTY: The Parker B310PDC Contour Probe is warranted against malfunction due to defective material and or workmanship. The defective unit will be repaired or replaced (less incoming freight charges) for a period of one year from the date of sale. This repair warranty does not apply to altered units.

The **BATTERY PACK** is warranted against defects in materials and workmanship for a period of three months from the date of purchase. **CAUTION:** Old Batteries should be disposed of in accordance with local ordinances.

Repair or replacement of the defective unit will be made at the discretion of Parker Research Corporation. Repaired or replacement unit(s) will be returned to the original customer prepaid.

The obligation of Parker Research Corporation is limited to the repair or replacement of the defective unit. No other obligation is expressed or implied. Parker Research Corporation assumes no liability from any claim arising from the use of this equipment.



CAUTION: For the correct and safe use of this equipment, training of operating personnel is required. Use of proper inspection procedures, standards compliance and safety requirements is the obligation of the user.

ALWAYS WEAR SAFETY GLASSES WHEN USING THIS EQUIPMENT

**PARKER RESEARCH CORPORATION
2642 ENTERPRISE ROAD WEST
CLEARWATER, FLORIDA 33763
U.S.A.**