



# OPERATING INSTRUCTIONS MODEL B300UF CONTOUR PROBES

BULLETIN 267-1  
Jun. 2016

## PARKER RESEARCH CORP.

NONDESTRUCTIVE TEST METHODS, SYSTEMS, INSTRUMENTS  
BOX 1406, DUNEDIN, FLORIDA, U.S.A. 34697  
PHONE: (727)796-4066 FAX: (727)797-3941

The B300UF Contour Probe is a rugged high performance instruments for Magnetic Particle inspection to accepted Nondestructive testing standards. Certain operating procedures and safety precautions should be observed.

**INSTRUMENT DESCRIPTION:** Basically, the B300UF Contour Probe is an electromagnet producing a strong magnetic field. Placement of the two poles (legs) upon ferrous metal provides a path for the intense magnetic field to pass from one pole to the other. The part completes the flux path and becomes highly magnetized. The model B300UF produces a strong constant AC field. All Parker Contour Probes are designed with flexible legs that allow the field to be "focused" at a precise area of inspection. The maximum leg spacing is 12" . (304.8mm). The B300UF Contour Probe comes equipped with a 25' (7.62 m) power cord.

The B300UF is for use on 115VAC 50-60 Hz, single phase grounded power source.

The model 14880R GFCI Plug is designed to break the electrical circuit from the B300UF in the event of damage to the instrument or power cord. The GFCI Plug should be tested before each use by following the instructions printed here and on the GFCI Plug.

1. Plug the GFCI into power receptacle.
2. Press Reset Button.
3. Press Test Button. Red Indicator should appear.
4. Press Reset Button again for use.
5. **CAUTION:** DO NOT USE IF TEST FAILS

### SPECIFICATIONS

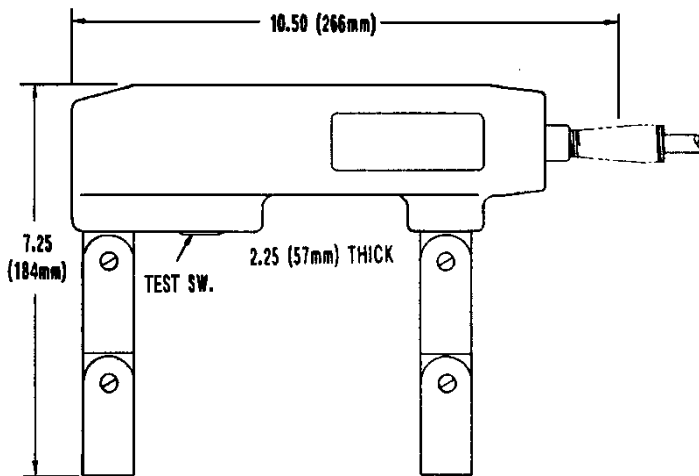

MODEL	POWER REQUIREMENTS	FIELD	WEIGHT
B300UF	115 VAC 50-60 Hz 6 AMPS	AC	7 lb (3.18 kg)

## GENERAL SAFETY RULES

Please read all instructions. Failure to follow all instructions listed below may result in injury. If the equipment is used in a manner other than as specified in these operating instructions, the protection provided by the equipment may be impaired. Always wear eye protection

**DO NOT OPERATE** unit from a DC power source.

Do not abuse the power cords. Never carry the instrument by the cord or attempt to unplug the instrument using the cord. Always operate the instrument with the standard installed cord. Changing or using a damaged cord can increase the risk of electrical shock. The cord should be checked periodically for any damage.

Do not position the instrument such that it would be difficult to operate the disconnect device (plug) on the end of the power cord.

The outside housing should remain intact and solid. Any damage, chipping, or separating exposing internal wires is a hazard. Instruments should not be used in this condition. The outside housing should be periodically checked for damage.

**!** **Duty Cycle:** The B300UF is designed for a 50% duty cycle, or approximately two minutes on and two minutes off. Continuous operation may cause overheating and damage the Contour Probe.

**Operating Environment:** Temperature: 32° to 104°F (0° to 40°C). Relative humidity: 10% to 95%, non-condensing

**Shipping and Storage Environment:** Temperature: 40° to 140°F (4.44° to 60°C). Relative humidity: 5% to 95%. Vibration and shock: As encountered in normal shipping and handling with no degradation.

### General Cleaning

The outside surface of the instrument can be periodically wiped clean with a clean cloth and a mild general purpose cleaner. Avoid using cleaners such as lacquer thinner, or mineral spirits that could damage the outside housing.

Never attempt field service. The B300UF Contour Probe should be returned to the factory for repairs.

**OPERATION:** Connect the GFCI instrument plug into a Grounded power outlet of proper voltage. Place the Contour Probe legs upon the work surface with the suspected defect at right angles to the legs (Good contact will produce the best results). Push the test switch to energize the instrument. Lightly dust or float dry magnetic inspection powder over the area being inspected. Defect indications will be revealed in a direction shown on figure 2. Turn the Probe 90 degrees from the first test and repeat the process. This method may also be utilized when applying a wet medium. Check all procedures and standards for further details involving inspection specifics.

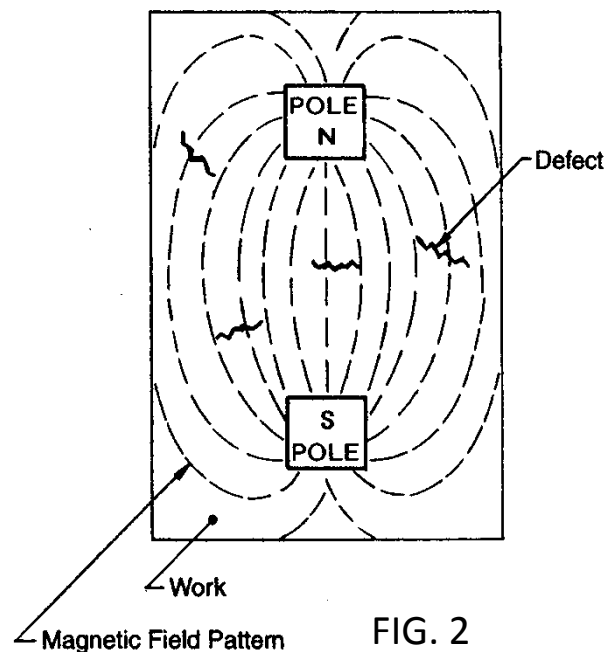

**DEMAGNETIZATION:** Small pieces, which have become residually magnetized, may be easily demagnetized by the following procedure: Energize the Probe and pass small parts through the area between the leg ends “feet” and withdraw to a distance of approximately two feet. On large pieces, place the Probe in the same position as inspection, energize the Probe and lift from the work surface to a distance of approximately two feet. This procedure may need to be preformed more than once to remove the residual field.

**AC MAGNETIZATION:** An AC magnetic field induced into a part is a “skin” or surface field and does not penetrate the cross section of the material. A by-product of AC is in the form of eddy currents. These eddy currents tend to guide or direct the magnetic field in a narrow pattern between the poles. Another by-product is a vibratory action, which adds mobility to the inspection particles to form a more highly defined powder build-up at the defect. For these reasons, an AC magnetic field is the most desirable for the detection of surface breaking defects.

 **CAUTION:** Small parts may become magnetically saturated due to excessive field application. This may cause a masking effect to the point where it is impossible to define a defect.

**WARRANTY:** The Parker B300UF is warranted against malfunction due to defective material and or workmanship. The defective unit will be repaired or replaced (less incoming freight charges) for a period of one year from the date of sale. This repair warranty does not apply to altered units. Repair or replacement of the defective unit will be made at the discretion of Parker Research Corporation. Repaired or replacement unit(s) will be returned to the original customer prepaid.

The obligation of Parker Research Corporation is limited to the repair or replacement of the defective unit. No other obligation is expressed or implied. Parker Research Corporation assumes no liability from any claims arising from the use of this equipment.

 **CAUTION:** For the correct and safe use of this equipment, training of operating personnel is required. Use of proper inspection procedures, standards compliance and safety requirements is the obligation of the user.

**ALWAYS WEAR SAFETY GLASSES WHEN USING THIS EQUIPMENT**

**PARKER RESEARCH CORP.  
2642 ENTERPRISE ROAD WEST  
CLEARWATER, FL 33763**