



**-OPERATING INSTRUCTIONS-  
Y300 & Y400  
PARKER PROBE LIGHTS**

**BULLETIN 196-1  
FEB 2009**

**PARKER RESEARCH CORP.**

NONDESTRUCTIVE TEST METHODS, SYSTEMS, INSTRUMENTS  
BOX 1406, DUNEDIN, FLORIDA, U.S.A. 34697  
PHONE: (727)796-4066 FAX: (727)797-3941

The Parker Y300 and Y400 Probe Lights are molded inspection lights designed to fit the B300, DA400, and B100 Contour Probes. The lights produce substantial close-in illumination for magnetic testing.

The Parker Probe Lights operate from the induction of the AC magnetic field produced by the Contour Probes. A small coil wound within the molded light housing produces 12 volts AC which operates the small cylindrical shaped bulb. There are no wiring connection necessary for installation. It should be noted that the lights operate in the AC mode only.

The Y300 Probe Light is designed to fit the rear leg housing of the Parker B300 Contour Probe while, the Y400 is designed to fit the rear leg housing of the DA400 and B100 Contour Probe. Both are molded from durable glass filled nylon which is extremely resistant to shock, wear and chemicals. The bulbs are an automotive dome light bulb which may be available from local sources. Replacements are also available from Parker at minimal cost.

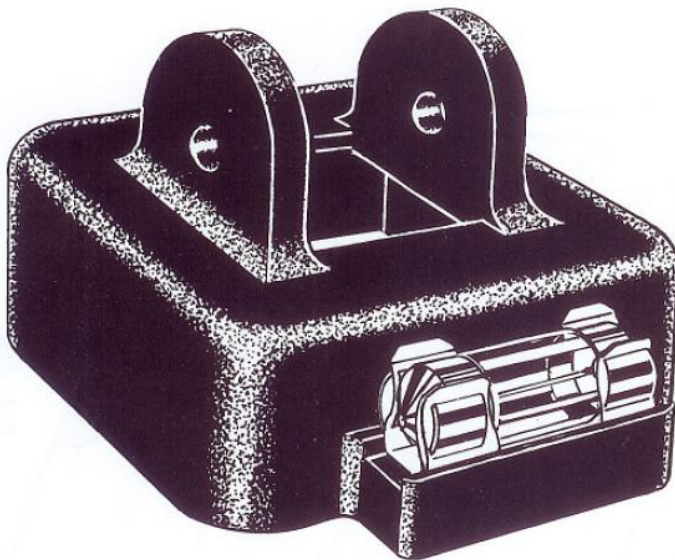

**Y300 Parker Probe Light  
Fits B300 Contour Probe**

**Y400 Parker Probe Light  
Fits DA400 Contour Probe  
& B100 Contour Probe**

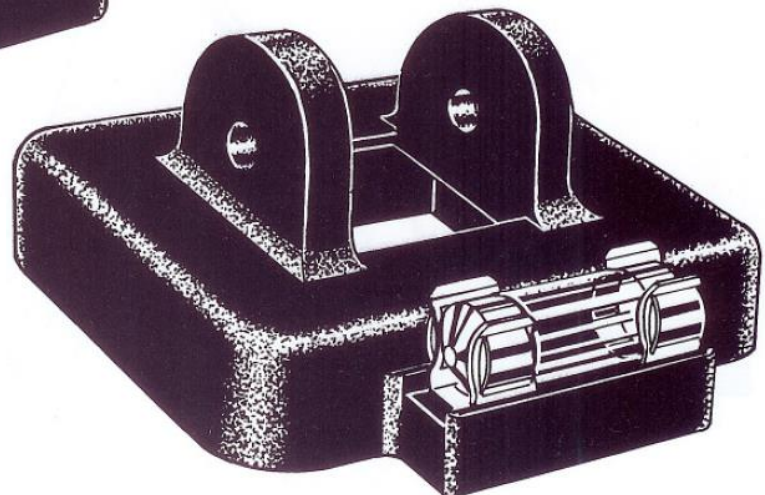

See reverse side for installation instructions.  
WEBSITE: [www.parkerndt.com](http://www.parkerndt.com)

**Y400 and Y300 Parker Probe Light**  
(For the Parker DA400, B300 and B100 Contour Probe)

**Installation Instructions:**

1. Remove existing screw and nut from rear Probe leg (closest to power cord).
2. Remove Probe leg.
3. Install Probe Light over leg attachment with light facing forward.
4. Reinstall rear Probe leg.
5. Insert new 1 3/4" screw using the washers on either side.
6. Attach nut and tighten.

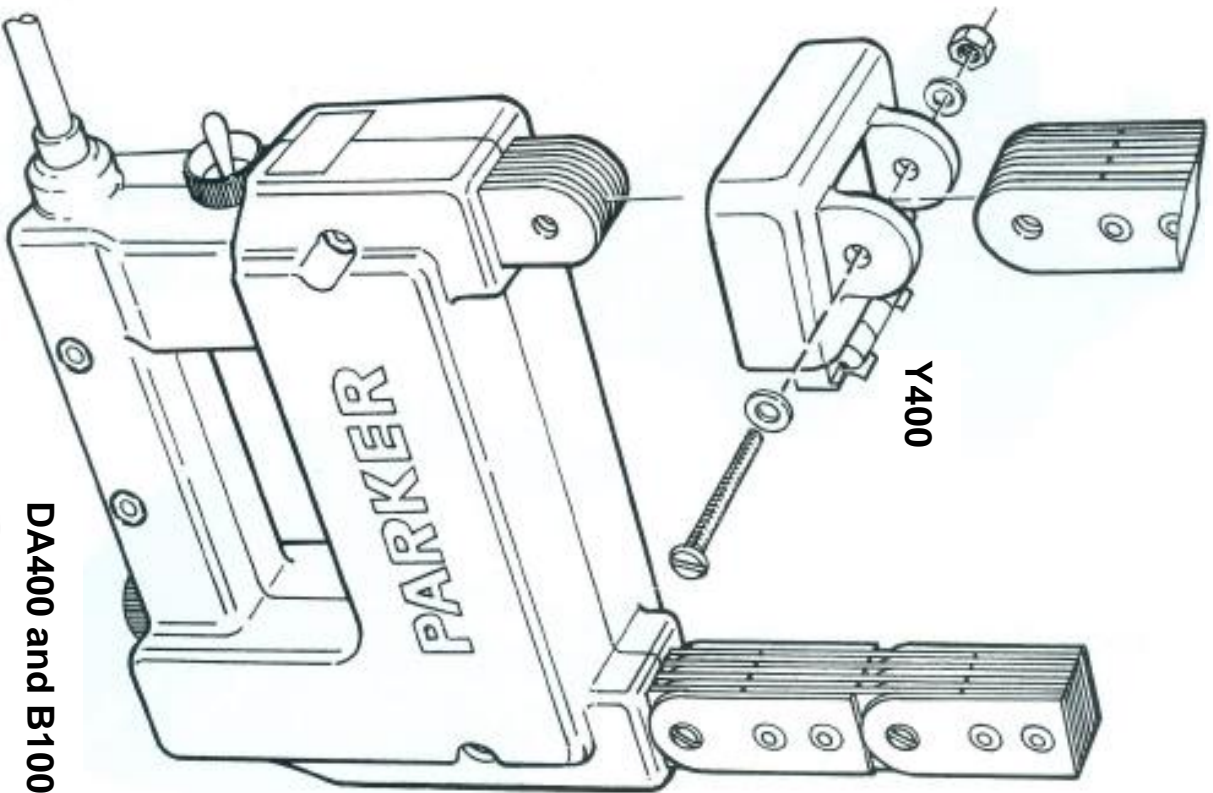

**DA400 and B100**

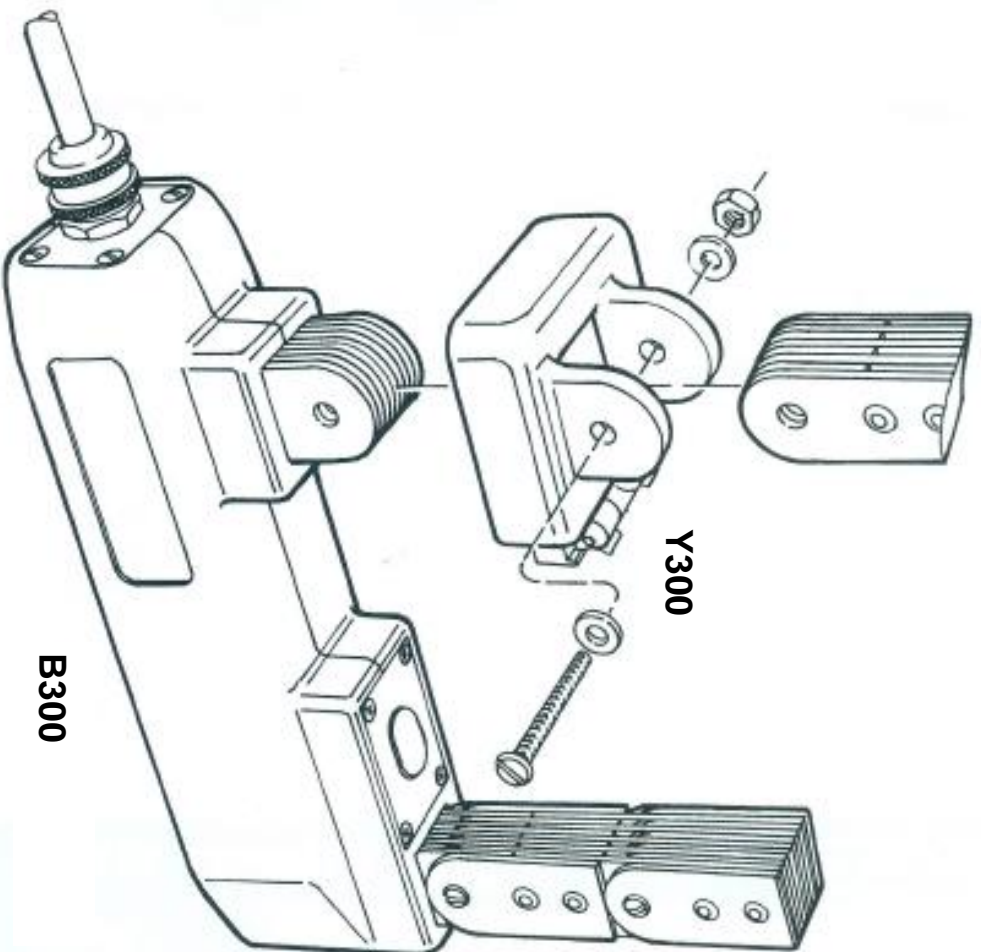

**B300**